

DYNABOX XL

Right angle
Servo gearheads
For heavy duty applications



Backlash down to 0,5 arc minute

DYNABOX XL



Torque up to
8000 Nm



GIRARD TRANSMISSIONS introduces :

DYNABOX XL

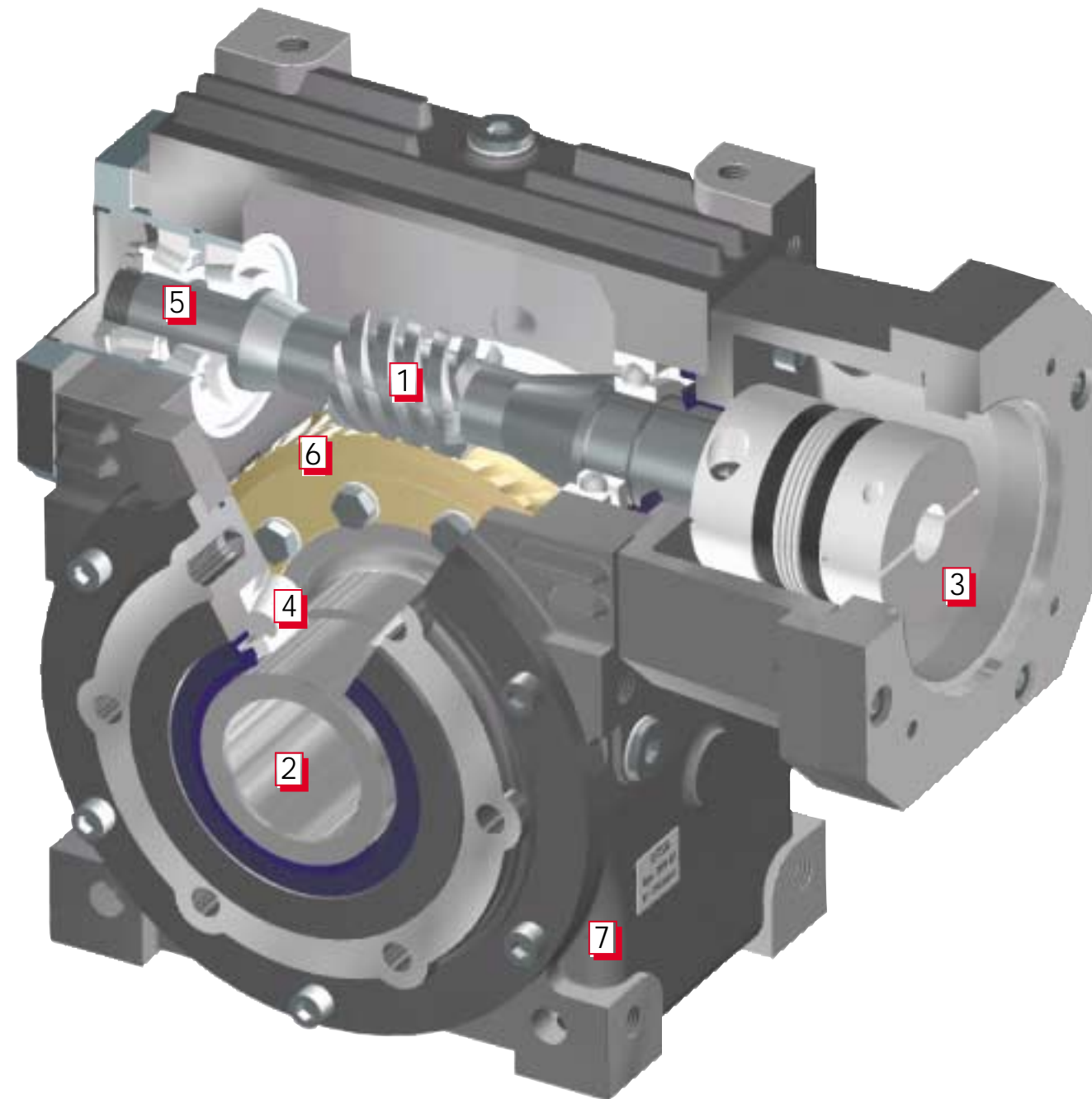

with 2 precision levels :

EXPERT : backlash < 0,5 arcminute
(adjustable)

MEDIUM : backlash < 5 arcminutes
(fixed)

- 1 Computer optimized gear contact pattern : less stress, longer life.
- 2 Keyless connection : reliable and backlash free connection with shrink disc.
- 3 Universal servo-kit : including high torsional stiffness coupling + flange.
- 4 Oversized taper roller bearings : provide very high permissible loads.
- 5 Constant input bearings preload design : 2 taper roller bearings + 1 floating ball bearings allowing temperature variations with same preload : higher input permissible speeds, longer life.
- 6 Centrifugally cast wheel ring : superior shock and wear resistance.
- 7 Cast iron housing

2 MOUNTING OPTIONS



Hollow shaft



Single output shaft

DYNABOX XL benefits

Low backlash

Space saving configuration : the right-angle design, more compact, is favourable in most cases.

Wormgear : very silent, more important permissible overloads, higher torsional stiffness.

Maintenance free : life-lubricated unit with high performances synthetic lubricant.

CONNECTING KIT *DYNABOX XL* -SERVOMOTOR

TORSION STIFF COUPLINGS

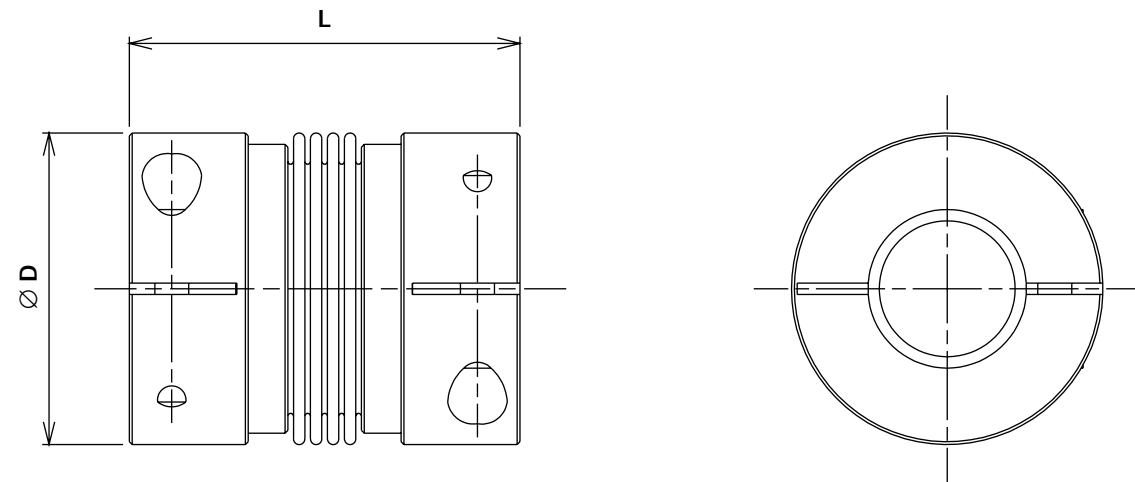

Coupling reference		AM N° 60	AM N° 80	AM N° 150	AM N° 300	AM N° 500
Ø servo shaft and <i>DYNABOX XL</i> shaft	mm	<Ø35	<Ø42	<Ø42	<Ø60	<Ø62
Servo nominal torque	Nm	60	80	150	300	500
Servo peak torque	Nm	90	120	225	450	750
Ø D	mm	66	82	82	110	123
L	mm	79	92	92	109	114
Polar moment of inertia	10 ⁻³ kgm ²	0,18	0,54	0,65	2,68	9
Torsional stiffness	Nm/mn	21	23	41	46	85

Specify the coupling reference and the servo shaft Ø when ordering.

Exemple : AM n° 150 Ø 42.

To calculate the input total inertia, add the coupling inertia to the gearbox inertia (page 5).

CONNECTING FLANGE

Select the required flange on page 11.

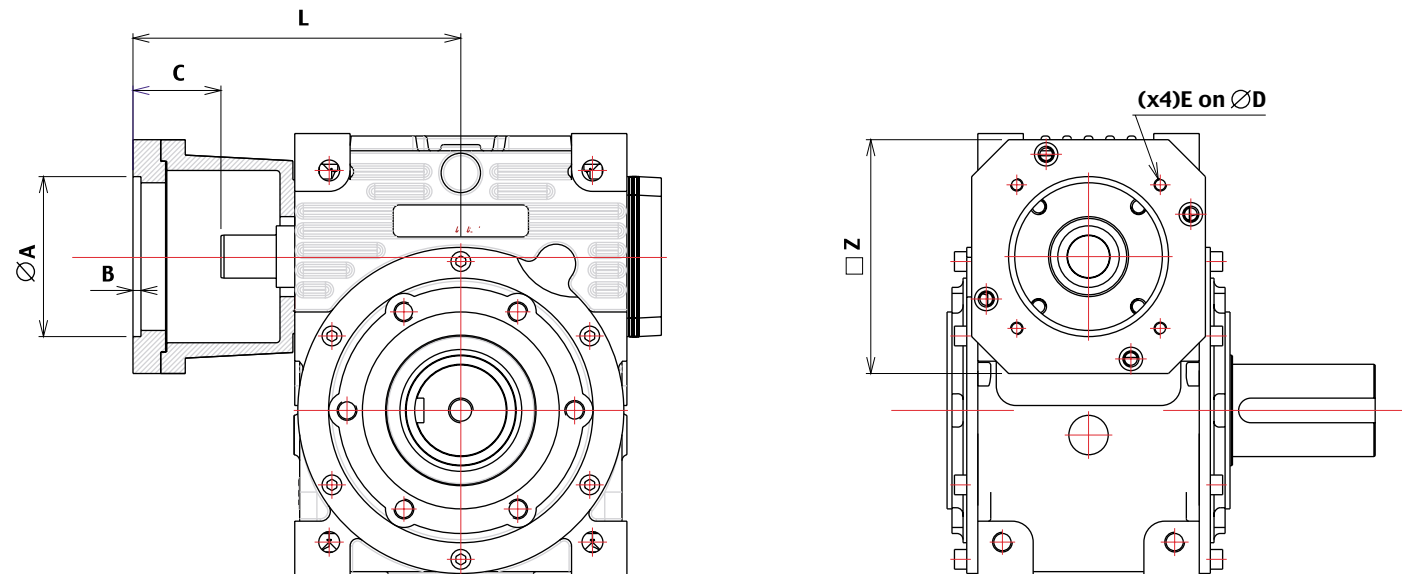

<i>DYNABOX</i>	Reference	A	B	C mini	D	E	L	Z
125	BM-F115/95	95	5	42	115	M8	247	190
	BM-F130/95	95	5	52	130	M8	257	190
	BM-F130/110	110	5	52	130	M8	257	190
	BM-F145/110	110	6,5	62	145	M8	267	190
	BM-F165/110	110	6,5	52	165	M10	257	190
	BM-F165/130	130	6,5	52	165	M10	257	190
	BM-F200/114,3	114,3	6,5	82	200	M10	287	190
	BM-F215/130	130	6,5	62	215	M12	267	190
	BM-F215/180	180	6,5	62	215	M12	267	190
	BM-F265/230	230	6,5	85	265	M12	290	260
	BM-F300/250	250	6,5	85	300	M14	290	260
	BM-F350/300	300	8,5	112	350	M16	317	360
160	BM-F165/130	130	6,5	52	165	M10	321	200
	BM-F200/114,3	114,3	6,5	82	200	M10	351	200
	BM-F215/130	130	6,5	62	215	M12	331	200
	BM-F215/180	180	6,5	62	215	M12	331	200
	BM-F265/230	230	6,5	85	265	M12	331	260
	BM-F300/250	250	6,5	85	300	M14	354	260
	BM-F350/300	300	8,5	112	350	M16	381	360
200	BM-F165/130	130	6,5	52	165	M10	365	200
	BM-F200/114,3	114,3	6,5	82	200	M10	399	200
	BM-F215/130	130	6,5	62	215	M12	379	200
	BM-F215/180	180	6,5	62	215	M12	379	200
	BM-F265/230	230	6,5	85	265	M12	402	260
	BM-F300/250	250	6,5	85	300	M14	402	260
	BM-F350/300	300	8,5	112	350	M16	429	360
	BM-F400/350	350	10,5	142	400	M16	460	420